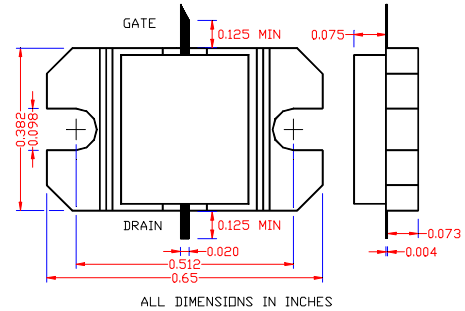

Not recommended for new designs. Contact factory. Effective 03/2003
18.15-18.75GHz, 2W Internally Matched Power FET

- 18.15-18.75GHz BANDWIDTH AND INPUT/OUTPUT IMPEDANCE MATCHED TO 50 OHM
- EIA FEATURES HIGH PAE(25% TYPICAL)
- EIB FEATURES HIGH IP3(46dBm TYPICAL)
- +33.0/+32.5dBm TYPICAL P_{1dB} OUTPUT POWER FOR EIA/EIB
- 6.0/5.0dB TYPICAL G_{1dB} POWER GAIN FOR EIA/EIB
- NON-HERMETIC METAL FLANGE PACKAGE

ELECTRICAL CHARACTERISTICS (T_a = 25 °C)

SYMBOLS	PARAMETERS/TEST CONDITIONS	EIA1818-2P			EIB1818-2P			UNIT
		MIN	TYP	MAX	MIN	TYP	MAX	
P_{1dB}	Output Power at 1dB Compression f=18.15-18.75GHz V _{ds} =8V, I _{dq} =0.5 I _{dss} (EIA), 0.6I _{dss} (EIB)	32.0	33.0		32.0	32.5		dBm
G_{1dB}	Gain at 1dB Compression f=18.15-18.75GHz V _{ds} =8V, I _{dq} =0.5 I _{dss} (EIA), 0.6I _{dss} (EIB)	5.5	6.0		4.5	5.0		dB
PAE	Power Added Efficiency at 1dB compression f=18.15-18.75GHz V _{ds} =8V, I _{dq} =0.5 I _{dss} (EIA), 0.6I _{dss} (EIB)		25			20		%
I_{d1dB}	Drain Current at 1dB Compression		880			850		mA
IP3	Output 3 rd Order Intercept Point f=18.15-18.75GHz V _{ds} =8V, I _{dq} =0.5 I _{dss} (EIA), 0.6I _{dss} (EIB)		40			46*		dBm
I_{dss}	Saturated Drain Current V _{ds} =3V, V _{gs} =0V	1100	1440	1700	1100	1360	1700	mA
G_m	Transconductance V _{ds} =3V, V _{gs} =0V		1500			700		mS
V_p	Pinch-off Voltage V _{ds} =3V, I _{ds} =12mA		-1.0	-2.5		-2.0	-3.5	V
BV_{gd}	Drain Breakdown Voltage I _{gd} =4.8mA	-13	-15			-15		V
R_{th}	Thermal Resistance (Au-Sn Eutectic Attach)		8			8		°C/W

*Typical -45dBc IM3 at P_{out}=23dBm/Tone

MAXIMUM RATINGS AT 25°C

SYMBOLS	PARAMETERS	ABSOLUTE ¹	CONTINUOUS ²
V_{ds}	Drain-Source Voltage	12V	8V
V_{gs}	Gate-Source Voltage	-8V	-3V
I_{ds}	Drain Current	I _{dss}	I _{dss}
I_{gsf}	Forward Gate Current	180mA	30mA
P_{in}	Input Power	32dBm	@ 3dB Compression
T_{ch}	Channel Temperature	175°C	150°C
T_{stg}	Storage Temperature	-65/175°C	-65/150°C
P_t	Total Power Dissipation	17W	14.2W

Note: 1. Exceeding any of the above ratings may result in permanent damage.

2. Exceeding any of the above ratings may reduce MTTF below design goals.